

PV-ezRack®

By Clenergy 

Ascent

Installation Guide V1.1

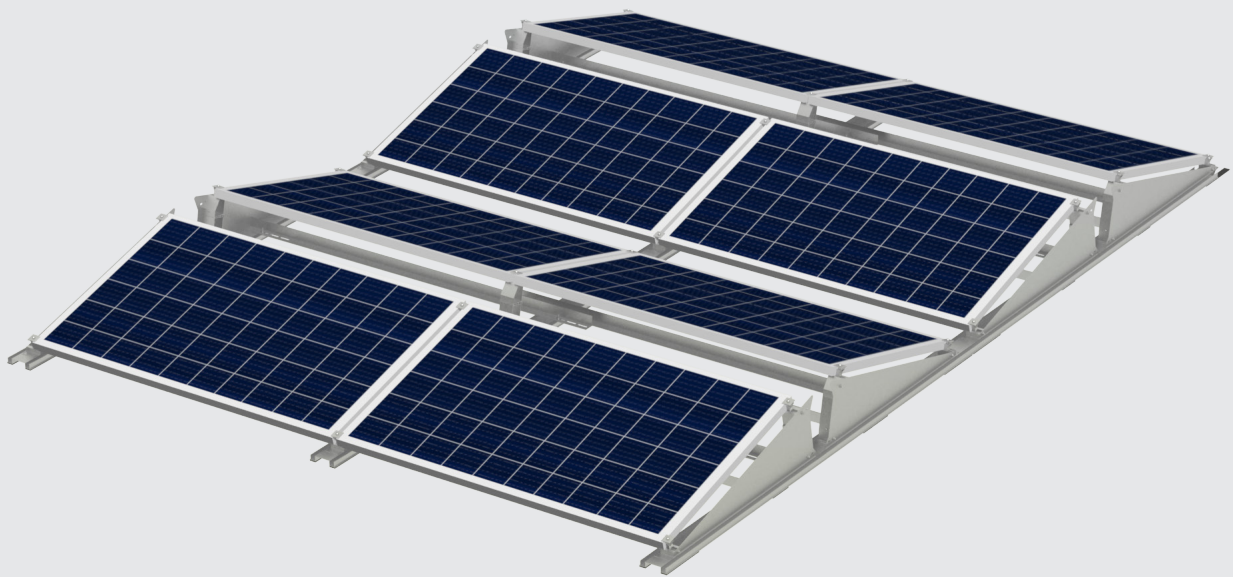

1. Introduction

PV-ezRack Ascent is widely used for PV-Module mounting on flat roofs. To make it robust and longevity, it is manufactured from aluminium alloy and stainless steel.

Please review this manual thoroughly before installing PV-ezRack Ascent. This manual provides:

- (1) Simple introduction of the installation relating to PV-ezRack Ascent Mounting systems;
- (2) Planning and installation instructions for PV-ezRack Ascent.

List of Contents

Introduction	01
Tools & Components	02
System Overview	03
Installation Instruction	05

The PV-ezRack Ascent parts, when installed in accordance with this guide. During installation, and especially when working on the roof, please comply with the appropriate Occupational Health and Safety regulations. Please also pay attention to any other relevant State or Federal regulations. Please check that you are using the latest version of the Installation Manual, which you can do by contacting Clenergy via www.clenergy.com or contacting your local distributor.

The installer is solely responsible for:

- Complying with all applicable local or national building codes, including any updates that may supersede this manual;
- Ensuring that PV-ezRack and other products are appropriate for the particular installation and the installation environment;
- Using only PV-ezRack parts and installer supplied parts as specified by PV-ezRack project plan (substitution of parts may void the warranty and invalidate the letter of certification);
- During installation, ensure that the self-tapping screws and metal screw have sufficient strength and shear force;
- Keep the roof waterproof system intact;
- Recycling: Recycle according to the local relative statute;
- Removal: Reverse installation process;
- Ensuring that there are no less than two professionals working on panel installation;
- Ensuring the installation of related electrical equipment is performed by licenced electricians;
- The upper and lower limit of the torque of the locking screws must be checked regularly at least once a year.
- Changes and deviations from the planning documents must be approved by Clenergy.

2. Tools & Components

2.1 Tools



Marker pen



Screw Driver



Torque Wrench
(M6/M8)



Socket Wrench
(13mm)



Allen Key 6mm
(M8 Hexagon
Socket Screw)



Tape



String



Drive Bit
(6mm, 10mm)

2.2 Components



EC-M
End Clamp



IC-M
Inter Clamp

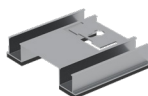

SEB-AC/120
Start and End Base L120

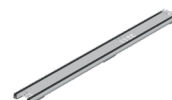

MB-AC/SN
Main Base, South-north

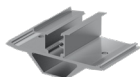

FL-AC/10 FL-AC/15
Front Leg 10°/15°



RL-AC/10
Rear Leg 10°



RLE-AC
Rear Leg Extension



WD-AC
Wind Deflector



SWD-AC
Side Wind Deflector



ER-AA-50/XXXX/50
Angle AL



GC-DT
Grounding Clip



EZ-GL-B
Grounding Lug

Note:

The tools in this chart are only used for installation of racking system (not included in supply scope), please consult system installation personnel about installation of electronic parts.

3. System Overview

3.1 Overview of PV-ezRack Ascent system

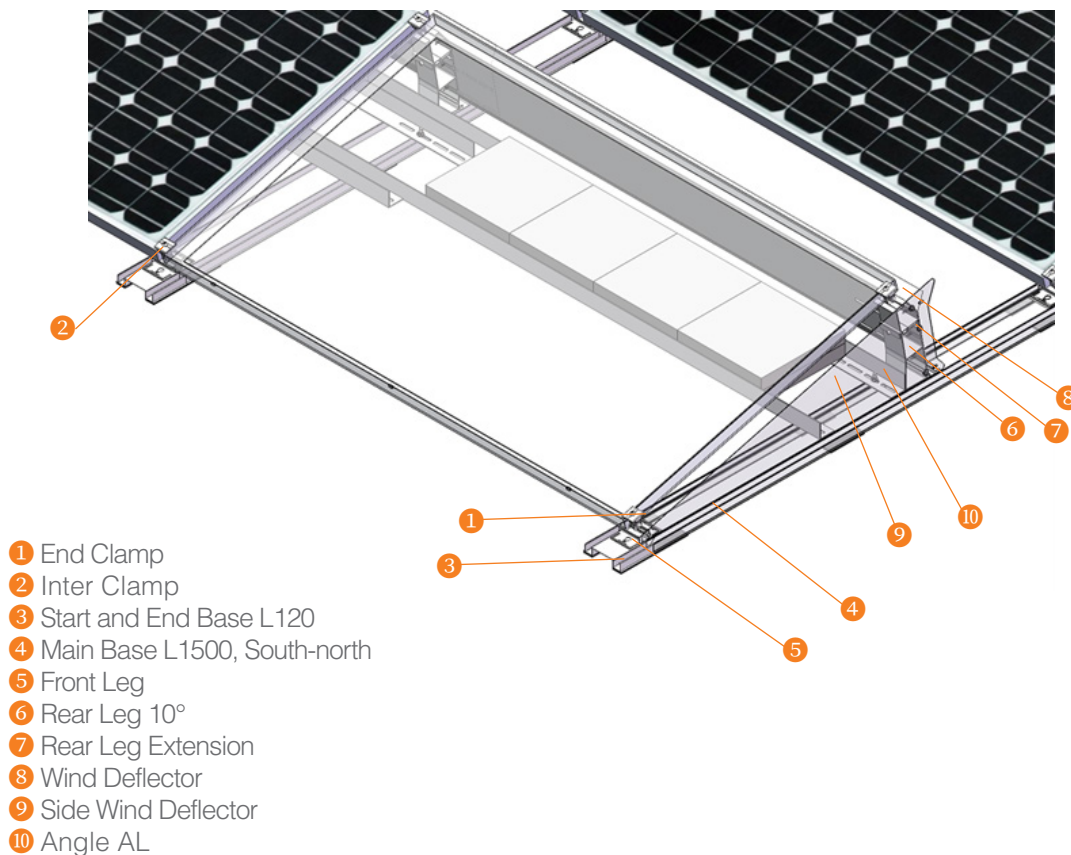

3.2 Precautions during Stainless Steel Fastener Installation

Improper operation may lead to deadlock of Nuts and Bolts. The steps below should be applied to stainless steel nut and bolt assembly to reduce this risk.

3.2.1 General installation instructions:

- (1) Apply force to fasteners in the direction of thread
- (2) Apply force uniformly, to maintain the required torque
- (3) Professional tools and tool belts are recommended
- (4) In some cases, fasteners could be seized over time. As an option, if want to avoid galling or seizing of thread, apply lubricant (grease or 40# engine oil) to fasteners prior to tightening.

3.2.2 Safe Torques

Please refer to safe torques defined in this guide as shown below. If power tools are required, Clenergy recommends the use of low speed only. High speed and impact drivers increase the risk of bolt galling (deadlock). If deadlock occurs and you need to cut fasteners, please make sure that there is no load on the fastener before you cut it. Avoid damaging the anodized or galvanized surfaces.

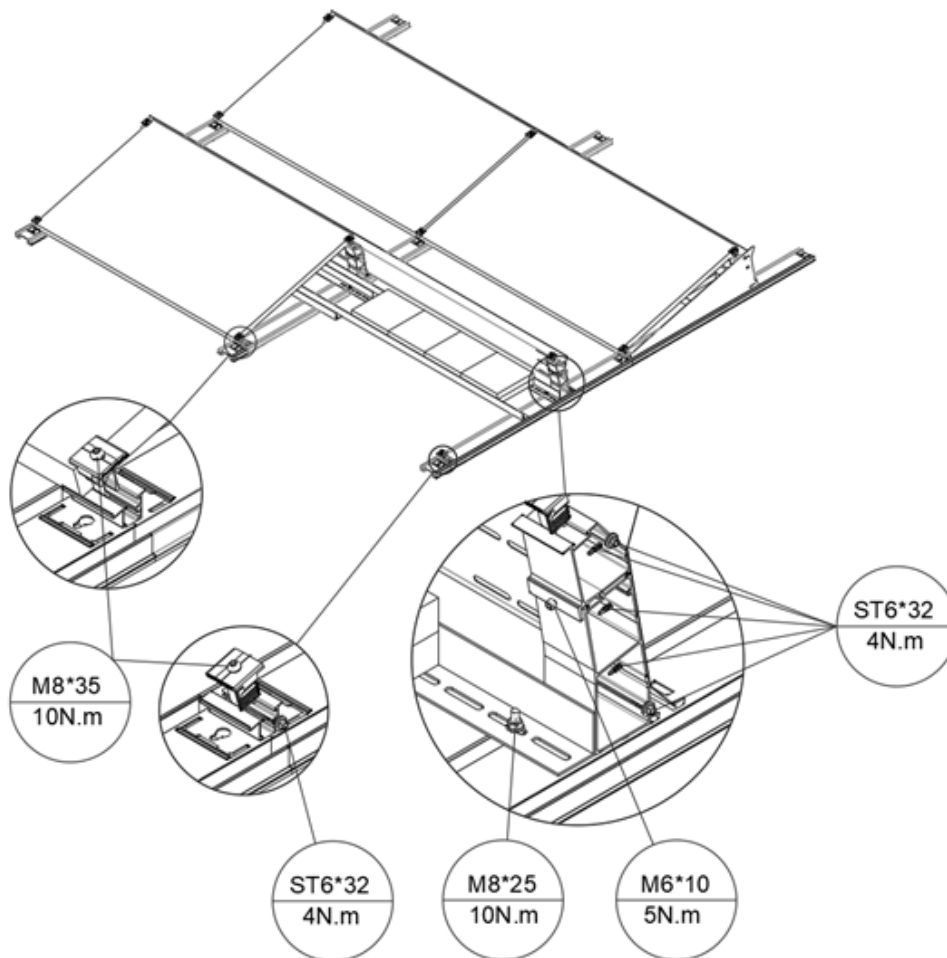

4. Installation Instruction

4.1 Base Installation

4.1.1 Mark the position of the Bases according to your plan.

4.1.2 Lay out the components, such as Start and End Base ③, Front Leg ⑤ and Main Base ④ according to your plan.

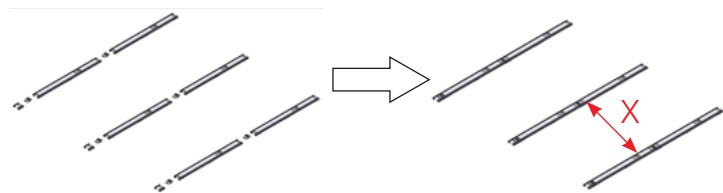

$X = \text{module length} + 20 \text{ mm} - 135 \text{ mm}$

The order of components in each row is: ③ ⑤ ④ ⑤ ④

And always end with Main Base at the end of the row.

4.1.3 Connect the Base ③ / ④ with the Front Leg ⑤ using the method shown in the right figure.

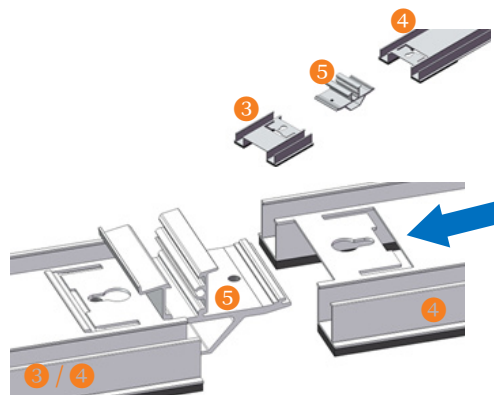

4.1.4 Place the Base on the marked position after installation.

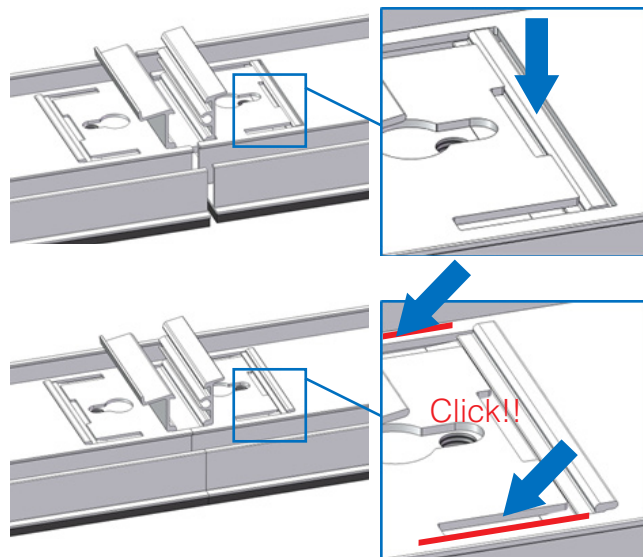

4.2 Rear Leg Installation

Install the Rear Leg 6 to the Main Base 4 using the method shown in the right figure.

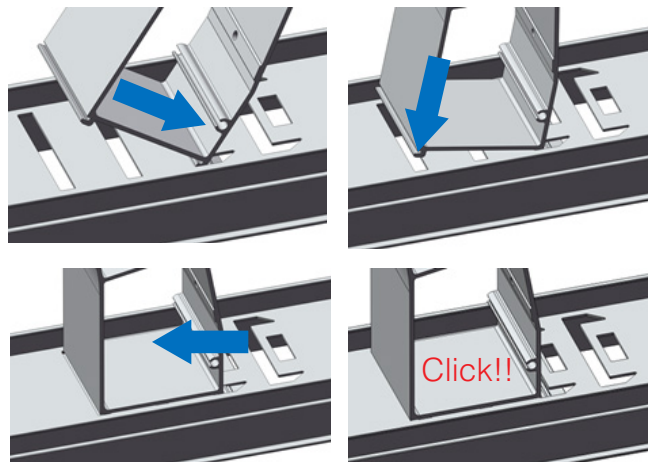
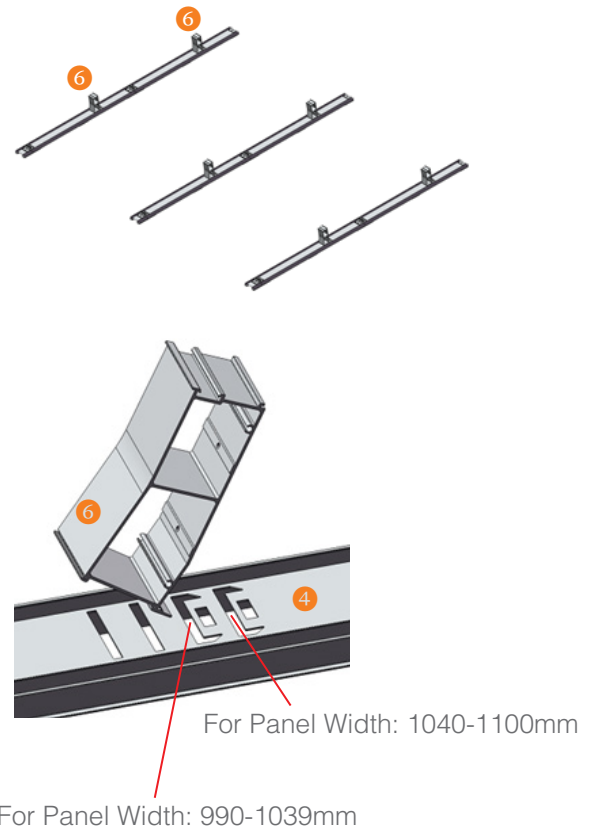

4.3 Rear Leg Extension Installation (For 15° system)

Install the Rear Leg Extension ⑩ to the Rear Leg ⑥ using the method shown in the right figure.

And then fix the M6*10 bolt with the torque of 5 N·m

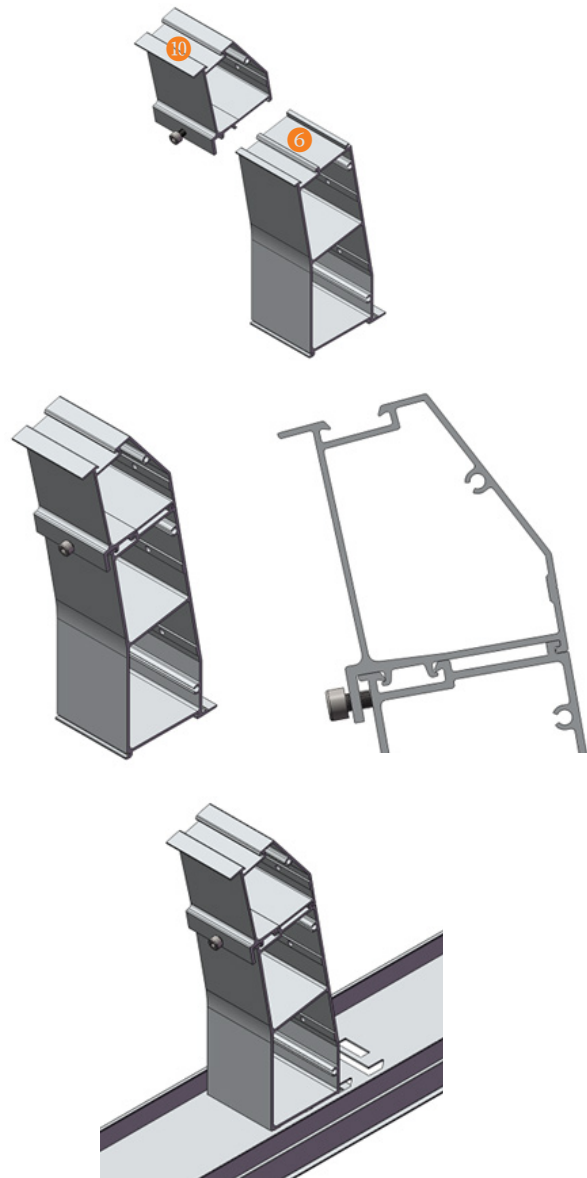

4.4 Placing the Ballast

4.4.1 Ballast per rail section.

Place the ballast centrally on Main Base.

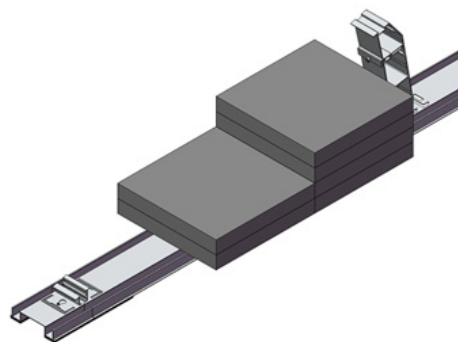

4.4.2 Ballast on double brace.

Place the ballast centrally on Angle AL when necessary.

Then fasten the nut with a torque of 10 N·m.

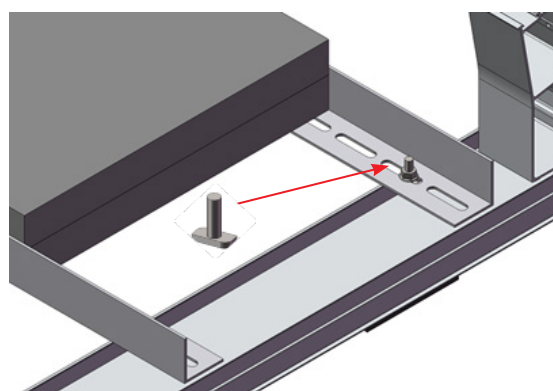
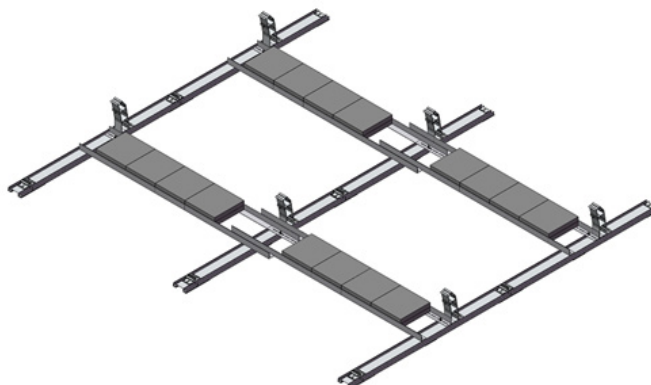

4.5 PV Modules Installation

4.5.1 Place the PV modules on the Front and Rear Leg. Leave a 20mm gap between PV modules for Inter Clamp.

4.5.2 Incline the Inter and End clamp to fit the top channel of Front and Rear Leg.

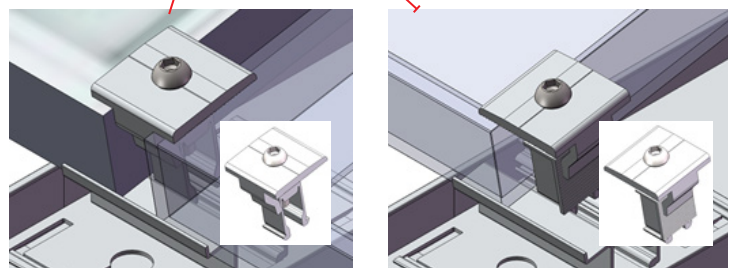
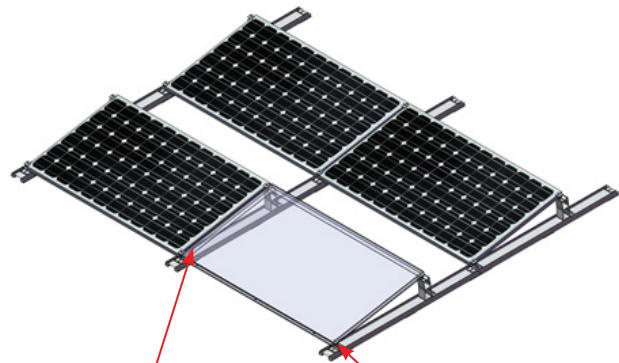

Press the Clamp down to securely fit into top channel until you hear a clicking sound. Fasten the hexagon socket screw with a torque of 10 N·m.

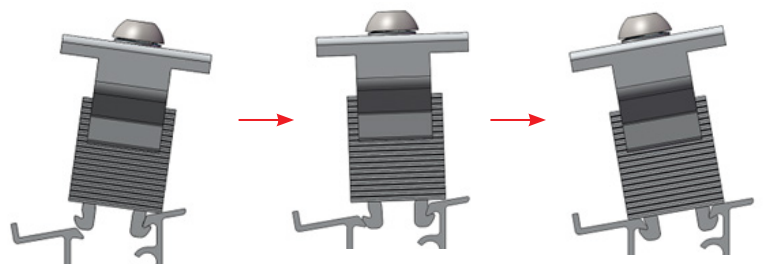

4.6 Wind Deflector Installation

4.6.1 Place back Wind Deflectors from left to right on the Main Base. Adjacent Wind Deflector are overlapping.

Align the first and last back Wind Deflector with the edge of the Rear Leg.

4.6.2 Screw the back Wind Deflector tight with ST6*32 screw.

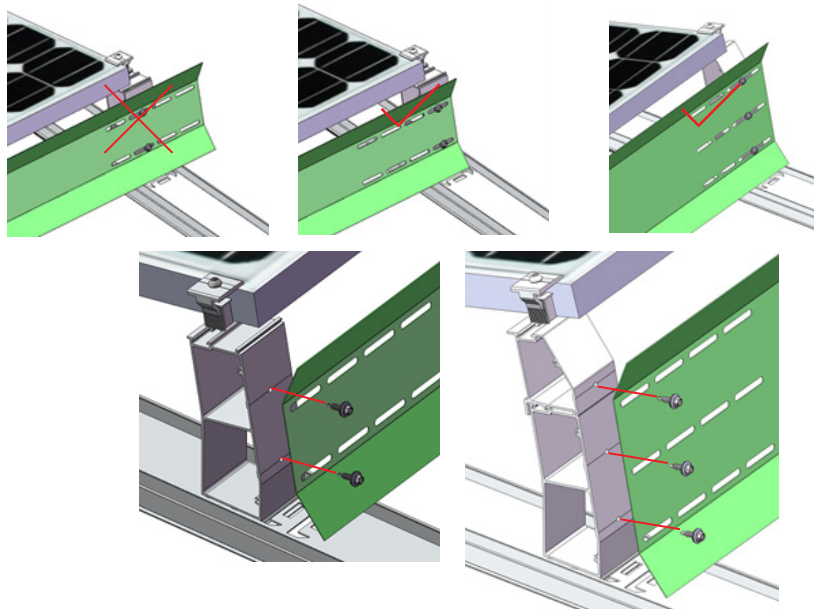

4.7 Side Wind Deflector Installation

4.7.1 Place Side Wind Deflector on the Main Base.

Note: Please pay attention to the direction .

Screw the Side Wind Deflector tight with ST6*32 screw.

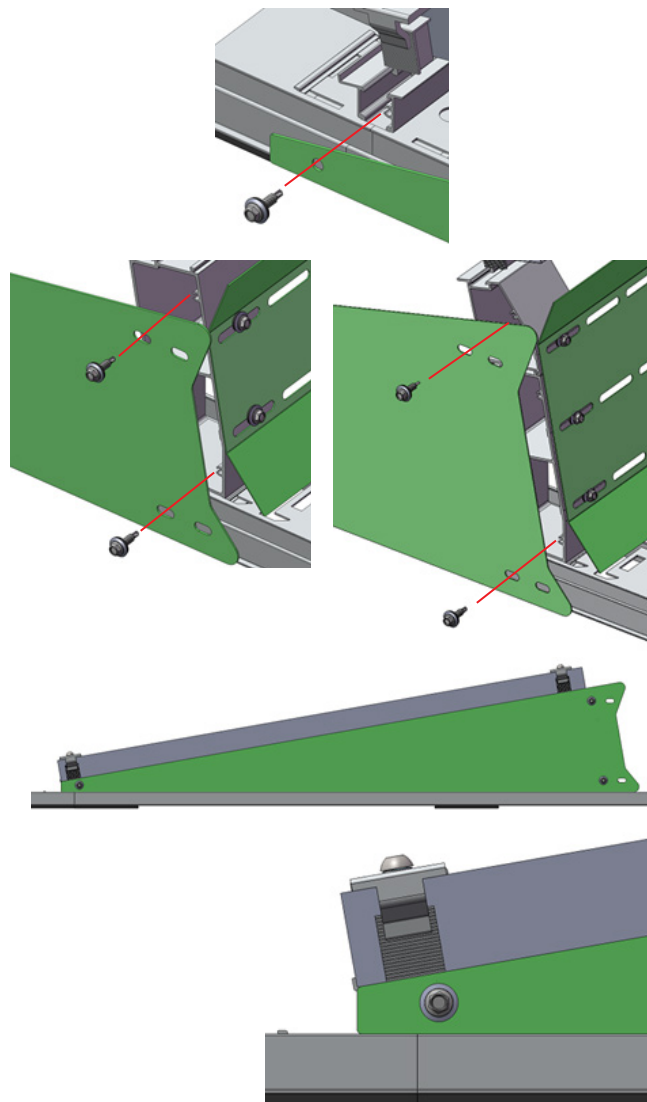

4.8 Grounding System Installation

4.8.1 Hexagon screw Installation

After the installation of Front Leg and Base, fasten Hexagon screws with the holes of front leg.

Note: It is required to install two Hexagon screws per Front Leg.

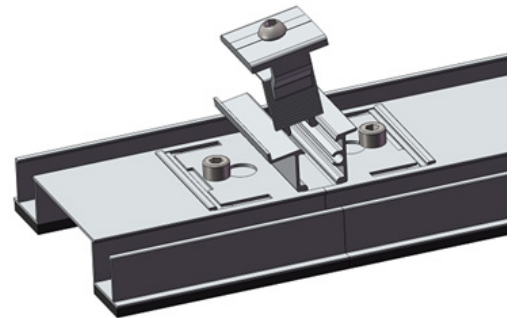

4.8.2 Grounding Clip Installation

Before module and clamps installation, it is important to arrange how to position grounding clips to achieve earthing continuity between each PV modules.

Place the PV modules on the Front and Rear Leg.

Incline the Inter and End clamp to fit the top channel of Front and Rear Leg.

Slightly lift the PV Module and slide Clamps and Grounding Clips into position. The teeth on Grounding Clip will automatically align when the Inter Clamp is properly installed as shown in figures on the right.

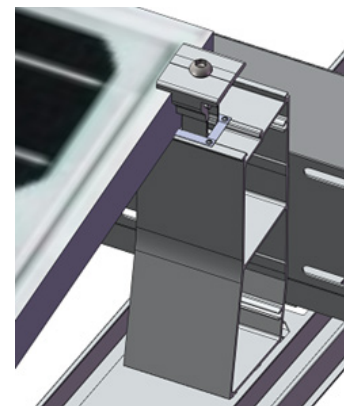
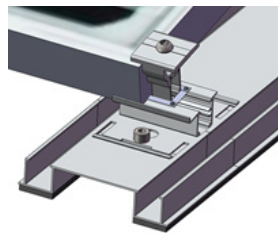

Install with Inter Clamp

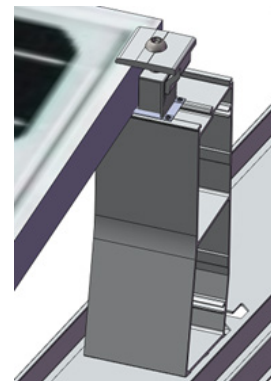
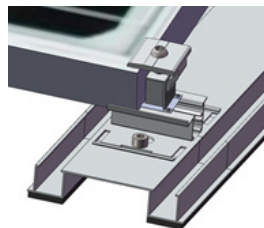

Install with End Clamp

4.8.3 Grounding Lug Installation

It is required to install one Grounding Lug per row of base. The recommended fasten torque of the bolt M6*14 is 5~6 N·m.

Fix the Grounding lug on the end of base. Make sure the inner face of side opening of Grounding lug is closely attach to the base as shown in right figure.

Strip earthing cable, insert the conductor into the Grounding lugs.

Recommended Torque: 5-6N·m

Note: If the earthing cable is less than 4mm, decrease the Torque to protect it.

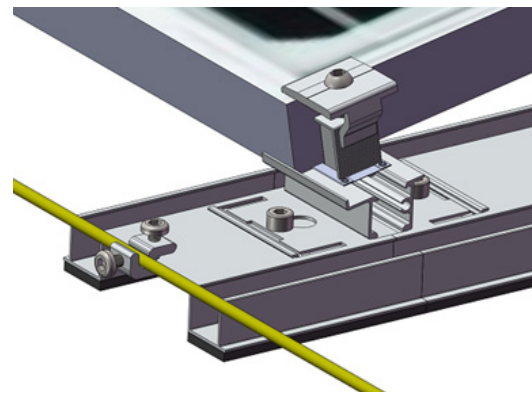
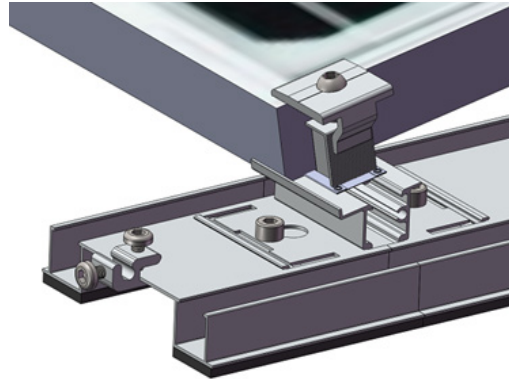

4.9 Final Inspection

4.9.1 Check that the complete system and all components have been installed according to the planning documents and that there are no deviations.

4.9.2 Check that all hexagon socket screws have been fastened according to the recommended torque (middle clamps, end clamps, Angle AL).

4.9.3 Check whether a sufficient weight of ballast has been applied in accordance with your plan.

4.9.4 Check all 'click connections' are correctly locked in place.



Innovating renewable energy

Clenergy Australia

1/10 Duerdin Street, Clayton VIC 3168 Australia
 Tel: +61 3 9239 8088 Fax: +61 3 9239 8024
 E-mail: sales@clenergy.com.au
www.clenergy.com.au

Clenergy China

999-1009 Min'an Rd, Huoju Hi-tech Ind. Dev. Zone
 Xiang'an District 361101, Xiamen, Fujian, China
 Tel: +86 592 311 0088 Fax: +86 592 599 5028
 E-mail: sales@clenergy.com.cn
www.clenergy.com.cn

Clenergy EMEA

Esplanade 41, 20354 Hamburg, Germany
 Tel: +49 (0) 40 3562 389 00
 E-mail: sales.emea@clenergy.com

Clenergy Japan

Nittochi Yamashita Building 5th Floor
 23 Yamashita-cho, Yokohama, 231-0023 Japan
 Tel: +81 45 228 8226 Fax: +81 45 228 8316
 E-mail: sales@clenergy.co.jp
www.clenergy.jp

Clenergy Philippines

145 Yakal St., San Antonio village, Makati City, Philippines
 Tel: +63 977 8407240
 E-mail: sales_ph@clenergy.com
www.clenergy.ph

Clenergy Thailand

9/2, 5th Floor, Vorasin Building, Soi Yasoo 2, Viphavadee-Rungsit
 Road, Chomphon Sub-district, Chatuchak District, Bangkok 10900
 Tel: +66 (0) 2 277 5201, +66 (0) 6 3228-0200
 E-mail: sales_th@clenergy.com, support_th@clenergy.com
www.clenergythailand.com

Clenergy Singapore

24 Raffles Place #28-01 Clifford Centre Singapore 048621
 Tel: +65 9873 8286
 E-mail: vincent.chan@clenergy.com

Clenergy Malaysia

Tel: +86 18750231005
 E-mail: sales_em@clenergy.com

Clenergy Vietnam

Tel: +65 9873 8286
 E-mail: sales_vietnam@clenergy.com

Clenergy Korea

Tel: +65 9873 8286
 E-mail: sales.kr@clenergy.com

Worldwide Network

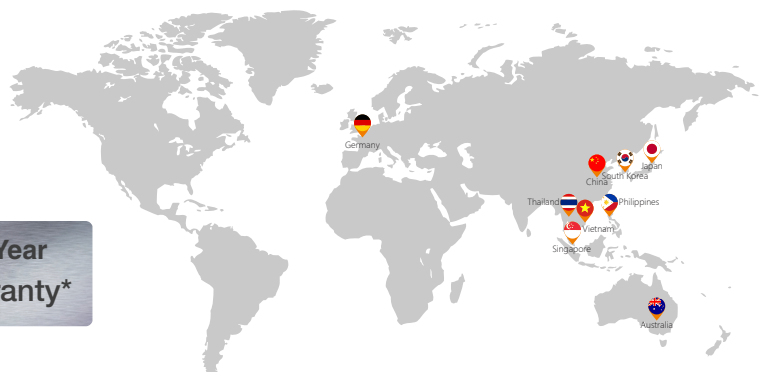

12 Year
 Warranty*